

Countersunk Phillips Post Anchor Barrel Nut

Thread Type: Metric - Coarse

Thread Direction: Right Hand

Drive Type: Phillips

Material: Stainless Steel

Class Grade: A4-70 G316

Corrosion Protection Level: Ultimate

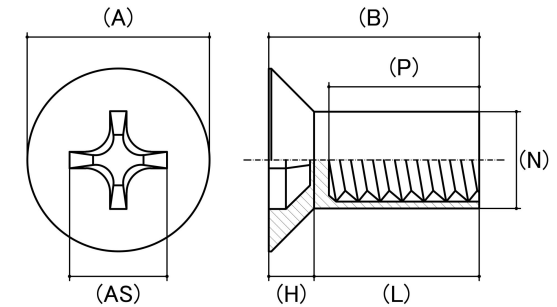

*CAD drawings shown for graphic representation only.**

Size	Thread Pitch (mm)	Thread Type	Overall Nut Height (B) (mm)	Barrel Length (L) (mm)	Head Diameter (A) (mm)		Head Height (H) (mm)		Body Diameter (N) (mm)		Driver Bit Size (AS)	sku (qfind)
			Nom	Nom	Min	Max	Min	Max	Min	Max	Nom	
M3	0.50	Coarse	20.00	18.10	7.35	7.55	1.70	1.80	3.80	3.90	PH2	41BNCPS320M
M5	0.80	Coarse	23.00	19.60	12.00	12.20	3.45	3.55	6.35	6.45	PH3	41BNCPS523M
M6	1.00	Coarse	25.00	21.80	13.75	13.85	3.70	3.80	7.85	7.95	PH3	41BNCPS625M
M8	1.25	Coarse	30.00	26.45	15.45	15.55	3.90	4.00	9.90	10.00	PH3	41BNCPS830M
M10	1.50	Coarse	30.00	26.80	19.20	19.50	3.45	3.55	11.85	11.95	PH4	41BNCPS1030M

Disclaimer:

Dimensional data and technical information was obtained from publically available sources and not acquired through standard agencies. It has been completed and compiled for reference purposes only; where discrepancies are found they are subject to change without notice. Bolt & Nut Australia makes no warranties or representations regarding the accuracy and validity of the compiled information and data. Contact the relevant standard authorities for accurate and detailed information.

* CAD drawings may not reflect diameter, thread length or overall length.

© Bolt & Nut Australia Pty Ltd. All rights reserved.

Version: 09 Apr 2024